

LEBENSSTIL

KOLLEKTION

Gas Hob **Instruction Manual**

LKGH-8602BR

LKGH-8603BR

LKGH-8602MB

LKGH-8603MB

Table of Contents

Components and Features	3
Description of the Appliances	5
How To Use Your Appliance	6
How To Keep Your Cooktop in Shape	8
Practical Advice	9
Safety is a Good Habit to Get Into	9
Is there a problem?	11
Installation Instructions for Built-In	12
CAUTION	19

Components and Features

- A. Work Burners
- B. Auxilliary Burners
- C. Support Grid for Cookware
- D. Control Knobs for Gas Burners
- E. Ignitor for Gas Burners
- F. Safety Device (only on certain models)

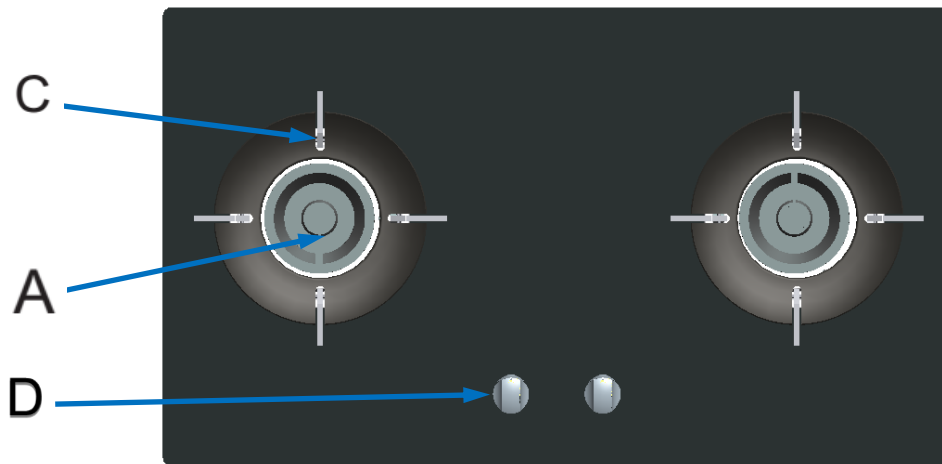
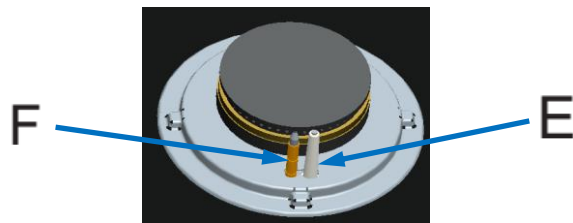

LKGH-8602BR

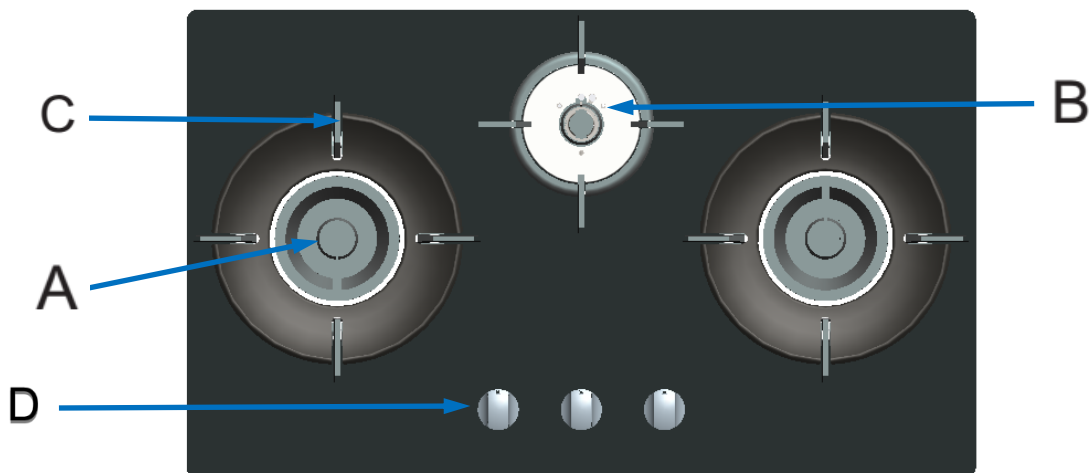

LKGH-8603BR

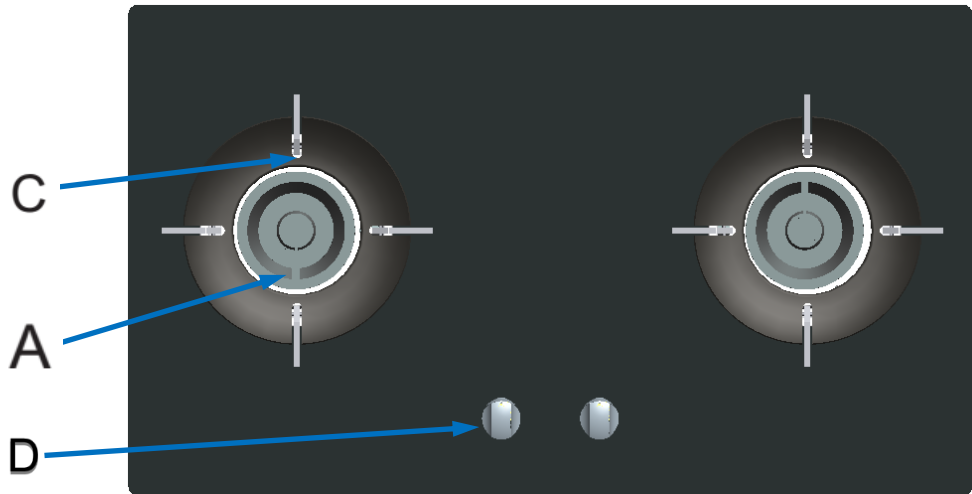

LKGH-8602MB

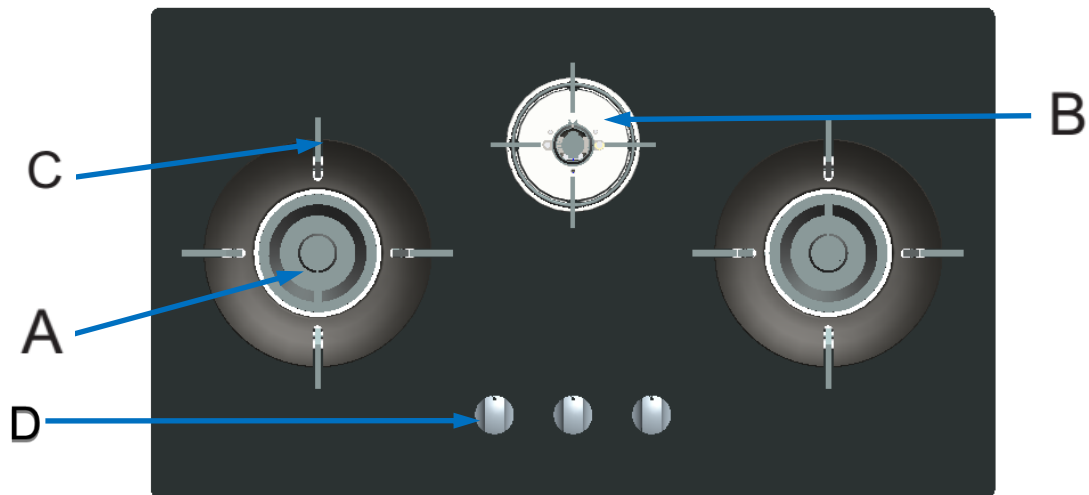

LKGH-8603MB

Description of the Appliances

The ranges of hotplates, which can be used built-in, are supplied with two or three burners with glass panel. Two work burners of Refer to the table below. Each burner, which is operated by a FSD/plug type gas valve, is controlled by metal control knobs positioned on the top of the panel. Each burner incorporates a flame supervision device (Thermocouple). The appliance incorporated a battery supply of 1.5V that operates the ignition system.

There are any types of knobs can be fitted on the appliance.

The detailed differences between the models are listed below:

Model number	Burner Variants			
	Work burner	Auxiliary burner	Total	Dimensions
LKGH-8602 BR	2	0	10kW(727g/h)	(760 X 450)mm
LKGH-8603 BR	2	1	10.9kW(792g/h)	(760 X 450)mm
LKGH-8602 MB	2	0	10kW(727g/h)	(860 X 500)mm
LKGH-8603 MB	2	1	10.9kW(792g/h)	(860 X 500)mm

Note: Work burner = Rated at 5.0kW.
Auxiliary burner = Rated at 0.9kW.

Burner	Injector size (mm)	Injector marking	Full rate
			kW
For LPG			
Work	Inner ring	0.58	58
	Outer ring	0.90	
Auxiliary	0.48	48	0.9

How To Use Your Appliance

The position of the corresponding gas burner is indicated on each control knob.

Gas Burners

The burners differ in size and power. Choose the most appropriate one for the diameter of the cookware being used.

The burner can be regulated with the corresponding control knob by using one of the following settings:

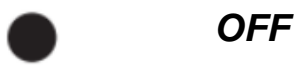

OFF





HIGH



LOW

Symbol description

Symbol 1		Use only a wok support supplied or recommended by the manufacturer of the appliance.
Symbol 2		Do not remove the pan support and enclose the burner with a wok stand as this will concentrate and deflect heat onto the hotplate.
Symbol 3		Locate pan centrally over the burner so that it is stable and does not overhang the appliance.
Symbol 4		Do not use a large pots or heavy weights which can bend the pan support or deflect flame onto the hotplate.
Symbol 5		Do not place anything, e.g, flame tamer, asbestos mat, between pan and pan support as serious damage to the appliance may result.

To turn on one of the burner, please deeply press the corresponding knob all the way in and turn in the counter-clockwise direction to the “high” setting.(On those models fitted with safety devices, user must keep the knob press down until the burner ignites for approximately 3 seconds to allow the safety device to heat up.)

Caution: If the burner accidently goes out, turn off the gas with the control knob and try to light it again after waiting at least 1 minute.

Caution:The user can turn the knob anti-clockwise from "High" position to "Low" position to reducing the power.Do not reduce the power by turning the knob from "High" position to "Off" position. It may lead to flame back and break the burner. It also may lead to gas have not fully combust, this gas may harm human health.

To Turn off a burner, turn the knob in the clockwise direction until it stops (it should be on the “●” setting).

Use the appropriate cookware, whose diameter is shorter than the hot plates’ for each burner in order to save energy.

How To Keep Your Cooktop in Shape

Before cleaning or performing maintenance on your appliance, disconnect it from the gas supply. **To extend the life of the cooktop, it is absolutely indispensable that it be cleaned carefully and thoroughly on a frequent basis, keeping in mind the following:**

Do not use steam equipment to clean the appliance.

The enameled parts and the glass top, if present, must be washed with warm water without using abrasive powders or corrosive substances which could ruin them;

The removable parts of the burners should be washed frequently with warm water and soap, making sure to remove caked-on substances;

On cooktops with automatic ignition, the end of the electronic ignition device must be cleaned carefully and frequently, making sure that the gas holes are not clogged;

Stainless steel can be stained if it remains in contact with highly calcareous water or aggressive detergents (containing phosphorous) for an extended period of time. It is recommended that these parts be rinsed thoroughly with water and then dried well. It is also a good idea to clean up any spills.

Greasing the Taps

The taps may jam in time or they may become difficult to turn. If so, the tap itself must be replaced.

N.B.: This operation must be performed by a technician authorized by the manufacturer.

Practical Advice

Practical Advice on Using the Burners

For best performance, follow these general guidelines:

Use the appropriate cookware for each burner (see table) in order to prevent the flame from reaching the sides of the pot or pan;

Always use cookware with a flat bottom and keep the lid on;

When the contents come to a boil, turn the knob to “Low”

Burner	Ø cookware diameter (cm)
Work Burners (A)	24-26
Auxiliary Burner (B)	12-22

Safety Is a Good Habit to Get Into

To maintain the Efficiency and Safety of this appliance, we recommend:

Call only the Service Centers authorized by the manufacturer, its service agent or similarly qualified persons in order to avoid a hazard.

Always use original Spare Parts.

This Manual is for a class 3 built-in or or class 2 built with oven beneath.

This appliance is designed for non-professional use in the home and its features and technical characteristics must not be modified.

These instructions are only valid for the countries the symbols for which appear on the manual and the serial plate.

Prevent children and the disabled from coming into contact or having access to the following, as they are possible sources of danger:

The controls and the appliance in general;

The packaging (plastic bags, polystyrene, nails, etc.);

The appliance, during the immediately after use given the heat generated by its use.

The appliance when on longer in installed (in this case, all potentially dangerous parts must be made safe).

The following should be avoid:

Using the appliance with bare feet;

Improper and/or dangerous use;

Obstructing the ventilation or heat dissipation slots;

Allowing the power supply cord of small appliances to come into contact with the hot parts of the cooktop.

Exposure to atmospheric agents (rain, sun);
Using flammable liquids nearby;
Using adaptors, multiple outlet plugs and/or extensions;
Using unstable or deformed cookware;
Trying to install or repair the appliance without the assistance of qualified personnel.

The assistance of qualified personnel must be called upon in the following cases:

Installation (in accordance with the manufacturer's instructions)
When in doubt about the operation of the appliance;

Contact service centers authorized by the manufacturer in the following cases:

When in doubt about the condition of the appliance after having removed the packing;
In the case of the breakdown or malfunction: ask for original spare parts.

It is recommended that you follow the guidelines below:

Only use the appliance to cook food, avoiding all other uses.
Check the condition of the appliance after it has been unpacked.
When not in use, take out the battery and turn off the gas valve (if present);
Always check to make sure that the control knobs are on the "●"/"○" setting when the appliance is not in use;

The manufacturer will not held liable for any damages arising out of : incorrect installation or improper, incorrect or unreasonable use.

Is there a problem?

It may occur that the cooktop does not function or does not function properly. Before calling customer service for assistance, let's see what can be done.

First of all, check to see that there are no interruptions in the gas and battery supplies, and, in particular, that the gas valves for the mains are open.

The burner does not light or the flame is not uniform around and burner.

Check to make sure that:

The gas holes on the burner are not clogged;

All of the movable parts that make up the burner are mounted correctly;

There are no draughts around and cooking surface.

The burner does not remain on when set to "Low".

Check to make sure that:

The Gas holes are not clogged.

There are no draughts near the cooking surface.

The minimum has been adjusted correctly (see the section entitled, "Minimum Regulation").

The cookware is not stable.

Check to make sure that:

The bottom of the cookware is perfectly flat.

The cookware is centered correctly on the burner.

The support grids have not been inverted.

If, despite all of these checks, the cooktop does not function properly and problem persists, call the nearest Customer Service Centre, informing them of:

The type of problem.

The abbreviation used to identify the model (Mod.) as indicated on the top panel warranty.

Never call upon technicians not authorized by the manufacturer or its service agent, and refuse to accept spare parts that are not original

Installation Instructions for Built-In

The following instructions are intended for the installer so that the installation and maintenance procedures may be followed in the most professional and expert manner possible.

Positioning

This appliance may only be installed and operated in permanently ventilated rooms in compliance with provisions laid down by current regulations and standards. The following requirement must be observed:

A) The room must be fitted with a ventilation system which vents smoke and gases from combustion to outside. This is must be done by means of a hood or electric ventilator that turns on automatically each time the hood is operated.

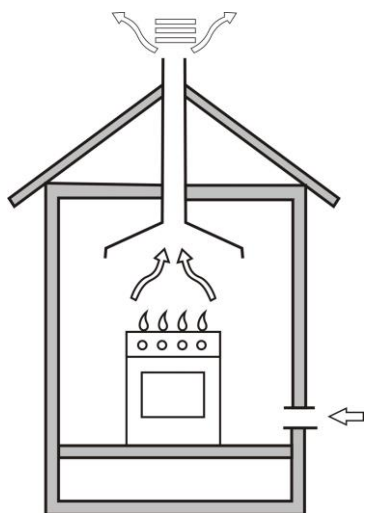

In a chimney stack or branched flue.
(exclusively for cooking appliances)

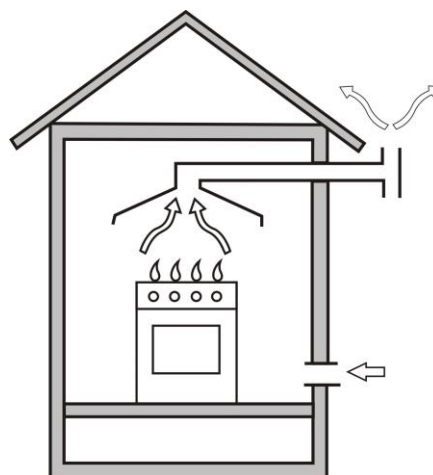

Directly to the Outside

B) The room must also allow for the influx of the air needed for proper combustion. The flow of air for combustion purposes must not be less than 2 m³/h per kW of installed capacity. The supply of said air can be effected by means of direct influx from the outside through a duct with a inner cross section of at least 100 cm² which must not be able to be accidentally blocked. Those appliances which are not fitted with a safety device to prevent the flame from accidentally going out must have a ventilation opening twice the size otherwise required, i.e.a minimum of 200 cm² (Fig. A). Otherwise, the room can be vented indirectly though adjacent rooms fitted with ventilation ducts to the outside as described above, as long as the adjacent rooms are not shared areas, bedrooms or present the risk of fire (Fig. B).

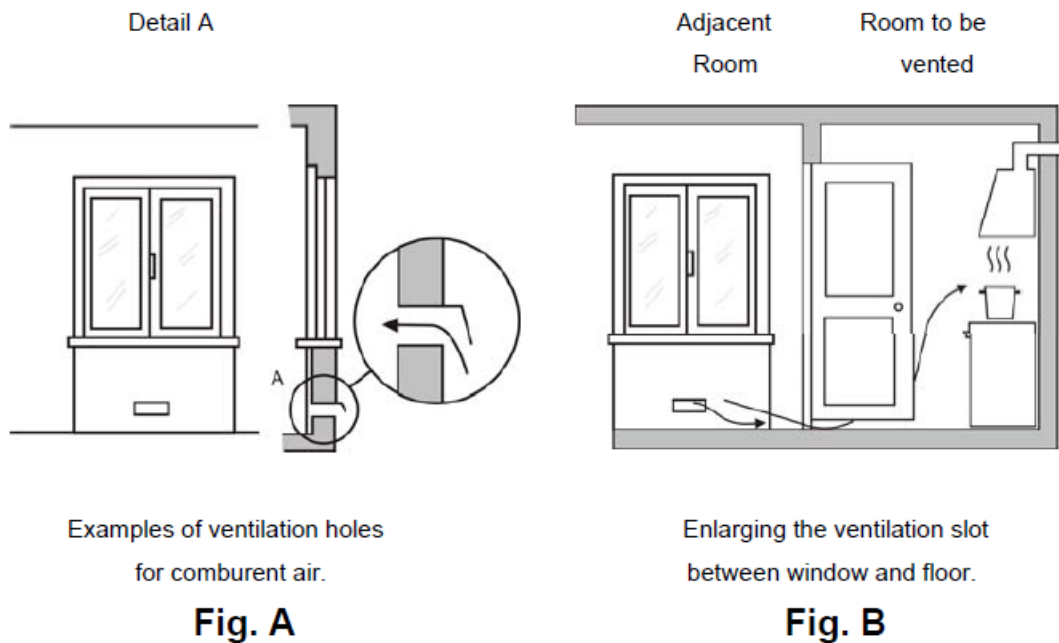

C) Intensive and prolonged use of the appliance may necessitate supplemental ventilation, e.g. opening a window or increasing the power of the air intake system (if present)

D) Liquefied petroleum gases are heavier than air and as a result, settle downwards. Rooms in which LPG tanks are installed must be fitted with ventilation openings to the outside in order to allow the gas to escape in the event of a leak. Therefore, LPG tanks, whether empty or partially full, must not be installed or stored in rooms or spaces below ground level (cellars, etc.). It is also a good idea to keep only the tank currently being used in the room, making sure that it is not near sources of heat (ovens, fireplaces, stoves, etc.) that could raise the internal temperature of the tank above 50°C

Installation of Built-In cooktops

The appliance can be installed next to furniture units which are no taller than the top of the cooker hob. The wall in direct contact with the back panel of the cooker must be made of non-flammable material. During operation the back panel of the cooker could reach a temperature of 50°C above room temperature. For proper installation of the cooker, the following precautions must be taken:

If the cabinet (s) located next to the cooktop are higher than the cooktop itself, the cabinet (s) must be installed at least 600 mm from the edge cooktop;

Hoods must be installed in the accordance with the instructions contained in the installation manual for the hoods themselves, and no less than 650 mm from the cooktop.

The cabinets installed next to the hood must be located at a height of at least 420 mm from the top, (as shown in Fig. C)

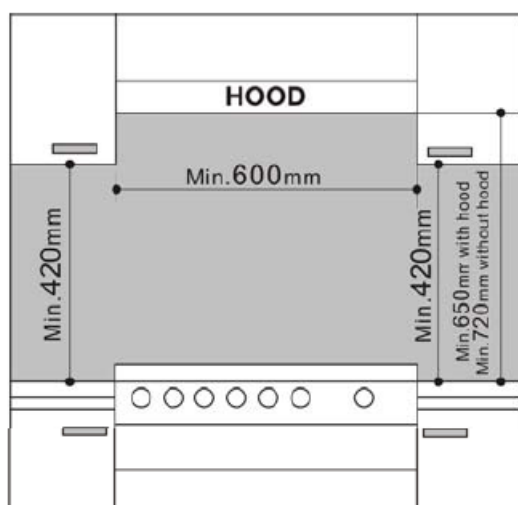
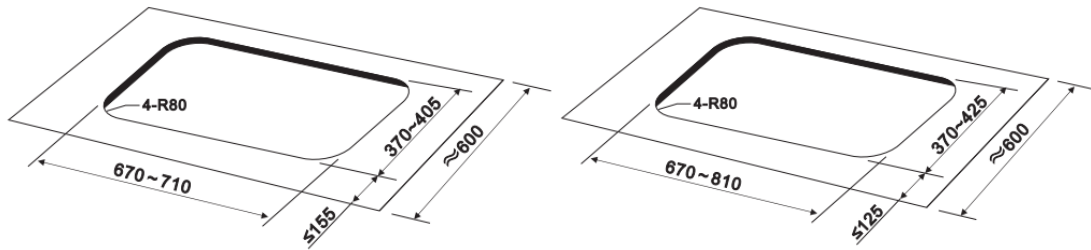

Fig. C

Should be cooktop be installed directly under a cupboard, later should be at least 720 mm (millimeters) from the top, as shown in Fig. C.

The dimensions of the cutout for the appliance must be those indicated in the figure D. Clamps are provided to fasten the cooktop to counters measuring from 20 to 60 mm in thickness. To fasten the cooktop securely, it is recommended that all the clamps be used.



LKGH-8602BR/LKGH-8603BR

LKGH-8602MB/LKGH-8603MB

FIG.D.

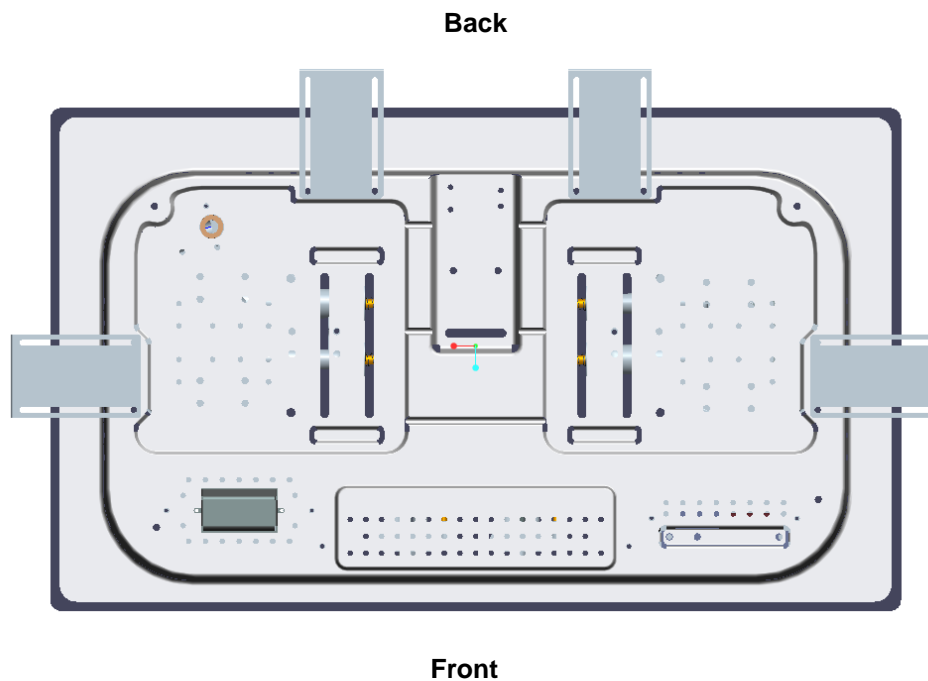

The hob can also be installed above built-in ovens provided with cooling ventilation.

In the event the cooktop is installed above a built-in oven, a wood panel must be inserted as insulation. This panel must be placed at about 50 mm from the bottom of the cooktop itself.

Important: When installing the cooktop above a built-in oven, the oven should be placed on two wooden strips; in the case of a joining cabinet surface, remember to leave a space of at least 45 x 560 mm at the back.

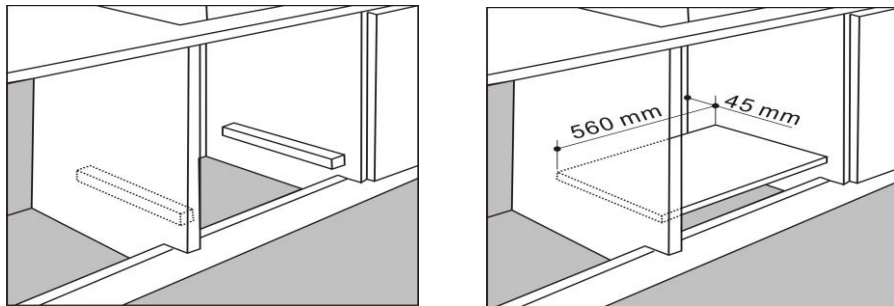

Installation of Built-In Cooktops on a CYLINDER COMPARTMENT

In the event the cooktop is installed above cylinder compartment, a wood panel must be inserted as insulation. This panel must be placed at about 50 mm from the bottom of the cooktop itself.

The opening of this compartment have to permit the easy introduction and removal of the cylinder. The dimension of the opening and the inside of the compartment shall be at least large enough to accommodate the cylinders (with regulator fitted) which are the most commonly used in the country. The total area of the opening in the upper part shall be at least 1/100 of the floor area of the compartment. The total area of the openings of the base shall be at least 1/50 of the floor area of the compartment. The cylinder support:

Shall have sufficient mechanical strength.

Shall not let the cylinder rest directly in the ground.

Shall not sill higher than the base on which the cylinder rests.

The cylinder tap have to be readily accessible.

Overflow of liquid from pans of the hotplate shall not fall onto cylinder or its accessories.

The flexible tube shall not be in contact with sharp edges. No internal communication shall exist between the cylinder compartment and the different parts of the appliance where burners are placed.

The ventilation openings of the compartment cannot be obstructed when the appliance is placed in position.

Gas Connection for Cooktop

The cooktop should be connected to the gas supply by an authorized installer. During installation of this product it is essential to fit an approved gas tap to isolate the supply from the appliance for the convenience of any subsequent removal or servicing. Connection of the appliance to the gas mains or liquid gas tanks must be carried out according to the safety standards currently in force, and only after it is ascertained that it is suitable for the type of gas to be used. If not, follow the instructions indicated in the section entitled, "Adapting the cooktop for Different Types of Gas". If the cooktop is to be connected to tanks containing liquid gas, use pressure regulators that comply with current safety standards.

Important: To insure that the appliance operates safely, the gas is regulated correctly and your appliance lasts overtime, make sure that gas pressure levels comply with the indications given , "Nozzle and Burner Specifications".

Gas connection to Non-flexible Pipe

(Copper or Steel)

Connection to the gas source must be done in such a way as to not create any stress points at any part of the appliance.

The appliance is fitted with an adjustable, "L" shaped connector and a gasket for the attachment to the gas supply. Should this connector have to be turned the gasket must be replaced (supplied with the appliance).

The gas feed connector to the appliance is a threaded, male 1/2" connector for round gas pipe.

Gas Connection to Flexible Steel Pipe

The gas feed connector to the appliance is a threaded, male 1/2" connector for round gas pipe. Only use pipes, tubes and gaskets that comply with current safety codes. The maximum length of the flexible pipes must not exceed 2000 mm. Once the connection have been made, ensure that the flexible metal tube does not touch any moving parts and not crushed.

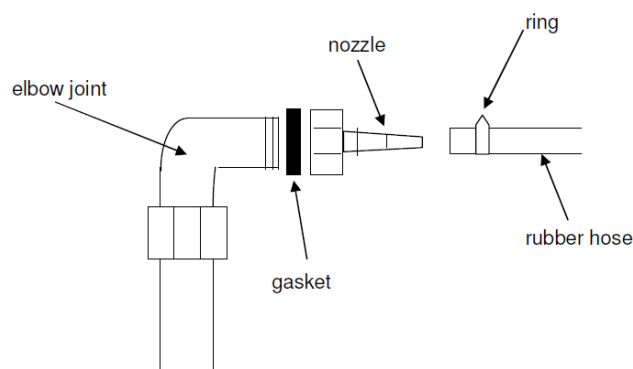

Check the Seal

Once the appliance have been installed, make sure all the connections are properly sealed, using a soapy water solution. Never use a flame.

How to load battery (on those models fitted with battery box)

Open the battery box, and then place a 1.5V size "D" battery into the box.(take notice of the direction)

Note:

- a) "prior to installation, ensure that the local distribution conditions (nature of the gas and gas pressure) and the adjustment of the appliance are compatible";
- b) "the adjustment conditions for this appliance are stated on the label (or data plate)";
- c) "this appliance is not connected to a combustion products evacuation device. It shall be installed and connected in accordance with current installation regulations. Particular attention shall be given to the relevant requirements regarding ventilation".

CAUTION: “In case of cooktop glass breakage: shut immediately off all burners and any electrical heating element and isolate the appliance from the gas supply do not touch the appliance surface, do not use the appliance.”

! CAUTION

! CAUTION: “In case of **cooktop** glass breakage: shut immediately off all burners and any electrical heating element and isolate the appliance from the **gas** supply do not touch the appliance surface, do not use the appliance.”

! CAUTION: The use of a gas cooking appliance results in the production of !heat, moisture and products of combustion" in the room in which it is installed. Ensure that the kitchen !is well ventilated especially when the appliance is in use": keep natural ventilation holes open or install a mechanical ventilation device (mechanical extractor hood).

! CAUTION: This appliance is for cooking purposes only. It must not be used for other purposes, for example room heating."

! CAUTION: “In case of hotplate glass breakage:

- shut immediately off all burners and any electrical heating element and isolate the appliance from the power supply
- do not touch the appliance surface
- do not use the appliance.”

Customer Careline
1-800-881-770

Distributed by,
Kollektion Distribution Sdn. Bhd.
Lot 11A, Jalan 223, Section 51 A,
46100, Petaling Jaya Selangor,
Malaysia