

LEBENSSTIL  
KOLLEKTION

## Instruction Manual

### Built-In Oven

Model: LKBO-4504CG

LEBENSSTIL  
KOLLEKTION

DISTRIBUTED BY:  
**Kollektion Distribution Sdn. Bhd.** (596854-A)  
Lot 11B, Jalan 223, Section 51A,  
46100 Petaling Jaya,  
Selangor Darul Ehsan, Malaysia.  
Tel:+603-7954 5200 Fax:+603-7954 5705

[www.kollektion.com.my](http://www.kollektion.com.my)

Careline  
1-800-881-770

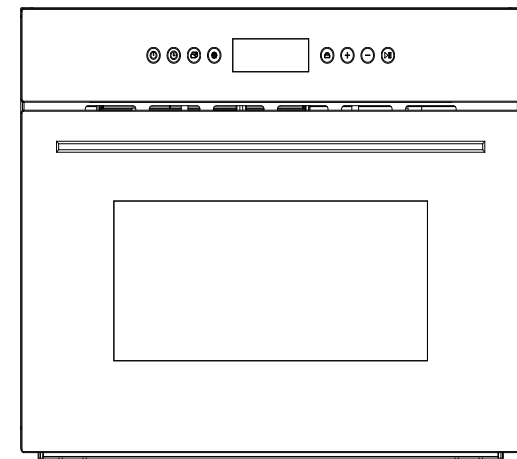

*Before operating this unit, please read these instructions completely.*

cables are suitable for the power absorbed by the appliance. The use of adapters, multiple sockets and /or extensions, is not recommended. If their use cannot be avoided, remember to use only single or multiple adapters and extensions which comply with current safety regulations . In these cases, never exceed the maximum current capacity indicated on the single adapter or extension and the maximum power indicated on the multiple adapter .The plug and socket must be easily accessible.

## 12 TECHNICAL SPECIFICATION

CAPACITY	35L
VOLTAGE (V)	220 - 240
FREQUENCY (Hz)	50/60
CIRCUIT BREAKER(A)	16
POWER (W)	2246 - 2673
PRODUCT DIMENSION (mm)	594 X 580 X 455
PACKAGE SIZE (mm)	670 X 663 X 525
GROSS/NET WEIGHT (Kg)	33.0/29.0

Notice:

- (1) Product Dimension is approximate number, the sequence is wide, deep, high.
- (2) Package size is peripheral package size of the box.
- (3) Physical parameters may be different from label because of our products is in continuous improvement, so please refer to physical parameters to make sure definite size.

You should contact professional person to dispose of products which you want to abandon

Do not throw away the products due to this will lead to hazards to the environment or other dangerous



- Fasten the wires beneath the screw heads using the following color scheme :Blue (N) Brown (L) Yellow-Green
- Fasten the supply cable in place with the clamp and close the cover of the terminal board.
- The ac power supply should be 220-240v, 50 Hz, the minimum 16 A distribution circuit fuse, or at least 16 a distribution circuit breaker.

## 11.2 Connecting the supply cable to the mains

Install a standardized plug corresponding to the load indicated on the data plate. When connecting the cable directly to the mains, install an Omni polar circuit breaker with a minimum contact opening of 3 mm between the appliance and the mains .The Omni polar circuit breaker should be sized according to the load and should comply with current regulations (the earth wire should not be interrupted by the circuit breaker).

The supply cable should be positioned so that it does not reach a temperature of more than 50°C with respect to the room temperature , anywhere along its length , or protected by insulation sleeping having an appropriate rating.

Before making the connection, check that:

- The electrical safety of this appliance can only be guaranteed if the cooker is correctly and efficiently earthed ,in compliance with regulations on electrical safety. Always ensure that the earthling is efficient; if you have any doubts call in a qualified technician to check the system .The manufacturer declines all responsibility for damage resulting from a system which has not been earthed.
- Before plugging the appliance into the mains, check that the specifications indicated on the date plate (on the appliance and /or packaging )correspond to those of the electrical mains system of your home .
- Check that the electrical capacity of the system and sockets will support the maximum power of the appliance, as indicated on the data plate. If you have any doubts, call in a qualified technician.
- If the socket and appliance plug are not compatible, have the socket replaced with a suitable model by a qualified technician. The latter, in particular, will also have to ensure that the cross sections of the socket

## CONTENTS

1 SAFETY PRECAUTIONS.....	4-5
2 MATTERS AND ATTENTIONS.....	5-6
3 DISPOSE OF REJECTED PRODUCTIONS.....	6
4 HOW TO USE YOUR OVEN.....	6-7
5 STRUCTURE DIAGRAM.....	7
6 DESCRIPTION OF FRONT PANEL CONTROLS.....	7-8
7 PROGRAMM AND FUNCTIONS.....	8-10
7.1 TIME SETTING.....	8
7.2 SETTING THE CURRENT TIME.....	8
7.3 SELECTING THE OVEN FUNCTION.....	8-9
7.4 DELAY TIME.....	9
7.5 PAUSE IN THE PROCESS OF BAKING.....	9-10
7.6 DEMO FUNCTION.....	10
7.7 CHILD LOCK.....	10
7.8 COOLING FAN SYSTEM.....	10
7.9 LAMP.....	10
8 OVEN FUNCTIONS.....	11-13
9 CLEANING AND MAINTENANCE.....	13-14
10 INSTALLATION.....	14-17
10.1 BEFORE THE INSTALLATION.....	14
10.2 INSTALLATION.....	15
10.3 INSTALLATION OF BUILT-IN OVENS.....	15-17
11 APPLIANCE CONNECTIONS.....	17-19
11.1 FITTING ON A POWER SUPPLY CABLE.....	17-18
11.2 CONNECTING THE SUPPLY CABLE TO THE MAINS.....	17-19
12 TECHNICAL SPECIFICATION.....	19

We recommend that you read the instructions in this owner's manual carefully before use for the best performance and to extend the life of your appliance, as it will provide you with all the instructions you require to ensure its safe installation, use and maintenance. Always keep this owner's manual close to hand since you may need to refer to it in the future. Thank you. Safety During operation.

## 1 SAFETY PRECAUTIONS

### IMPORTANT NOTICE : THIS PRODUCT MUST NOT BE LEFT UNATTENDED WHILE IT IS CONNECTED TO THE SUPPLY MAN.

- In order to avoid bump against people or oven when carrying the oven ,please grip the hand shank on the two external side. Do not carry in the shake hands handle place. This might damage the oven.
- To ensure your safety all electric appliance should only be installed or service by qualified staff. If the supply cord is damaged, it must be replaced by the manufacture, its service agent or similarly qualified staff in order to avoid a hazard.
- Do not place supply cord on the edge of table and counter, or touching heated appliance.
- In order to avoid electric shock, do not immerse supply cord ,plug or other parts into water.
- Do not place the production near electric stove, heated oven, microwave or other heat source.
- In order to avoid burn or explosion, combustibles (curtains, cloth, wallpaper and others) or packaged and canning should be removed.
- Do not place paperboard, plastic or other similar items in the oven. When the oven is not be used, everything should be removed except provided accessory.
- Do not cover slag pan or other parts with tinsel since it will result overheated.
- Accessible parts may become hot during use, children should be kept away.
- Never obstruct vents provided for ventilation and heat dispersal.
- The ends of door handle may become hot during use, so please grip the middle parts.
- Disconnect the oven from the power supply before cleaning or maintenance.
- When your oven is fault, please send it to nearest service agent to examine, repair or adjust.

**Note: the installation and handling, please do not use the handle for stress point.**

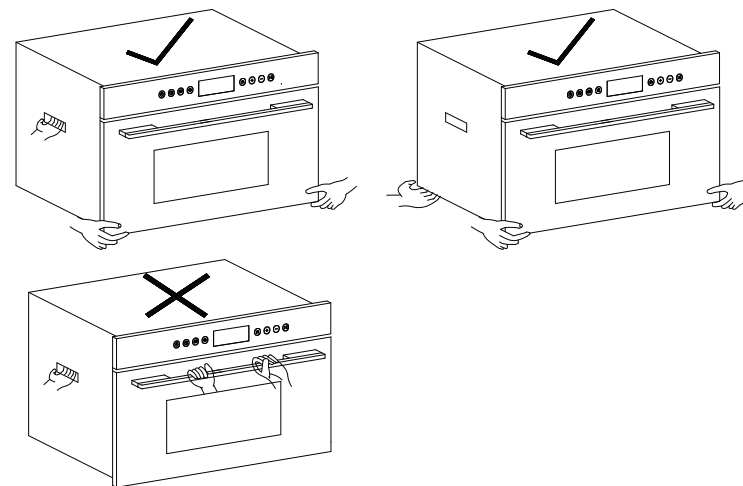

The panels of the adjacent cabinets must be made of heat-resistant material. In particular, cabinets with a veneer exterior must be assembled with glues which can withstand temperatures of up to 100°C.

In compliance with current safety standards, contact with the electrical parts of the oven must not be possible once it has been installed.

All parts, which ensure the safe operation of the appliance, must be removable only with the aid of a tool.

## 11 APPLIANCE CONNECTIONS

### 11.1 Fitting on a Power Supply Cable

Those ovens equipped with a three-pole power supply cable are designed to operate with an alternating current .The wire for earthing the appliance is yellow-green in color.

Opening the terminal board:

- Using a screwdriver, prize the bolt on the side tabs of the Terminal board cover;
- Unscrew the bolt, pull open the cover of the terminal board .

To install the cable, proceed as follows:

- Remove the wire clamp screw and the three contact screws L-N -

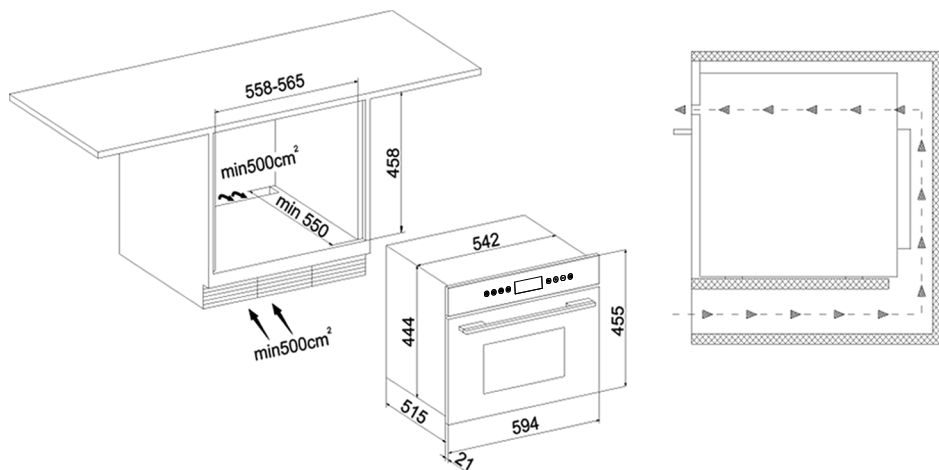

In order to fix the oven with cabinet, please open the oven door and insert four wood screws into the four holes around frame and fix them.

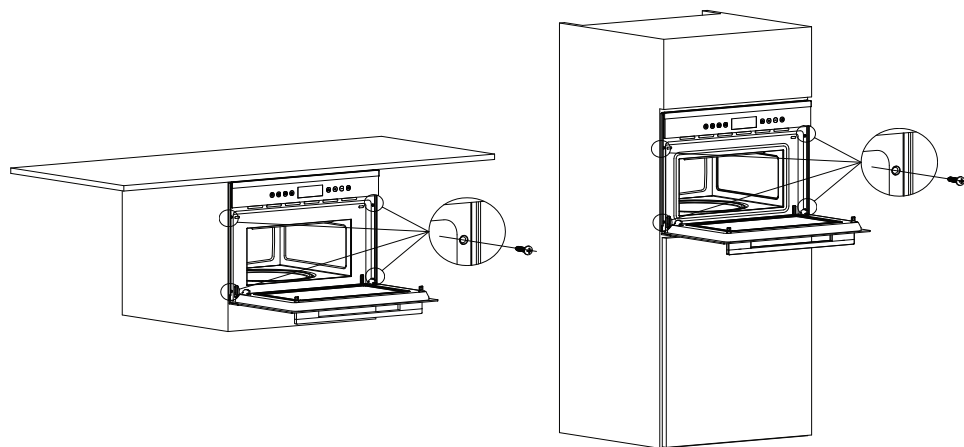

- Take insulation special gloves to carry ovenware or handle oil plate.
- Disconnect the oven from the power supply and waiting until it is cool , before cleaning.
- In order to avoid electric shock, please never use wiry brush to clean since pieces of metal is easy to touch live part.
- Never use metal scouring pads or sharp scrapers which will damage the door surface, and leading to glass broken.
- In order to avoid burn or electric shock, never putting too much food or metal utensils.
- Please make sure the oven has been closed when it is not be used, and only display clock mode.
- Unplug the socket when you are planning not to use the oven.
- Never use your oven outside.
- Other purpose except baking is not allowed.
- This equipment has the impact resistance, safe glass door; more than common glass can resist impact damage. Toughened glass if be destroyed, other parts will have sharp edges, please to avoid hand contact to the door of the surface of the broken glass or metal stents sharp edges. If the door glass already cataclysmic, please contact the dealer provide new replace glass.
- Do not lean on the opened oven door. This may damage the oven, especially in the hinge zone. The door can bear a maximum weight of 8 kg.

## 2 MATTERS AND ATTENTIONS

- Accessible parts may become hot during use, children should be kept away.
- In order to avoid electric shock, please make sure the oven has been shut off before replacing the lamp.
- Only use original accessories.
- Do not use wet parts of body to touch oven.
- Do not use the oven barefoot.
- Do not pull and push oven or supply cord, this may make socket disconnected.
- Improper or dangerous operations must be forbidden.
- Never obstruct vents provided for ventilation and heat dispersal.
- Do not let the power cord of other appliances touch the heated parts of oven.
- The oven should not be exposed to rain or sunshine.

- Do not use the oven as a pantry.
- Do not use flammable objects near the oven.

Distributors and users decline all liability for not following above instructions, brake components and parts and not use original accessories or some improper operations which caused personal injury and property loss.

### 3 DISPOSE OF REJECTED PRODUCTIONS

Please recycle the package since the materials are Eco-Friendly .In order to prevent children from stifle when playing with them; please do not discard plastic packaging.

Please send your rejected productions to Environmental Conservation Organization or authorized Electrical recycle bin, this will recycle useful materials and reduce the hazards of environment.

### 4 HOW TO USE YOUR OVEN

- 4.1 The first time you use your appliance, we recommend that set the thermostat to the highest setting and leave the oven on for about half an hour with nothing in it, with the oven door shut. Then open the oven door and let the room air in. The odor that is often detected during this initial use is due to the evaporation of substances used to protect the oven during storage and until it is installed.
- 4.2 Place the dripping pan provided on the bottom shelf of the oven to prevent any sauce and/or grease from dripping onto the bottom of the oven only when grilling food or when using the rotisserie (only available on certain models). For all other types of baking, never use the bottom shelf and never place anything on the bottom of the oven when it is in operation because this could damage the enamel. Always place your cookware (dishes, aluminum foil, etc. etc.) On the grid provided with the appliance inserted especially along the oven guides.
- 4.3 After baking food contains sugar and salt, please clean your oven promptly, or these will attach to the pan surface.
- 4.4 You can place the shelf in two side guide rail .Put a slice of bread directly on the rack (From down to third rail); Place specific small pan on the rack, food in the pan.

### 10.2 Installation

Only a qualified person in compliance with the instructions provided must install the appliance. Manufacturer declines all responsibility for improper installation, which may harm persons and animals and damage property.

- Important:
- The power supply to the appliance must be cut off before any adjustments or maintenance work is done on it;
  - Air duct is supposed to use in ventilation.
  - The ac power supply should be 220-240 v, 50/60 Hz, the minimum 16 A distribution circuit fuse, or at least 16 a distribution circuit breaker.

### 10.3 Installation of Built-in Ovens

If we put the oven into cabinet, the material cabinet should be insulated, and the clearance between the edge of the cabinet and the oven should be over 500mm for ventilation.

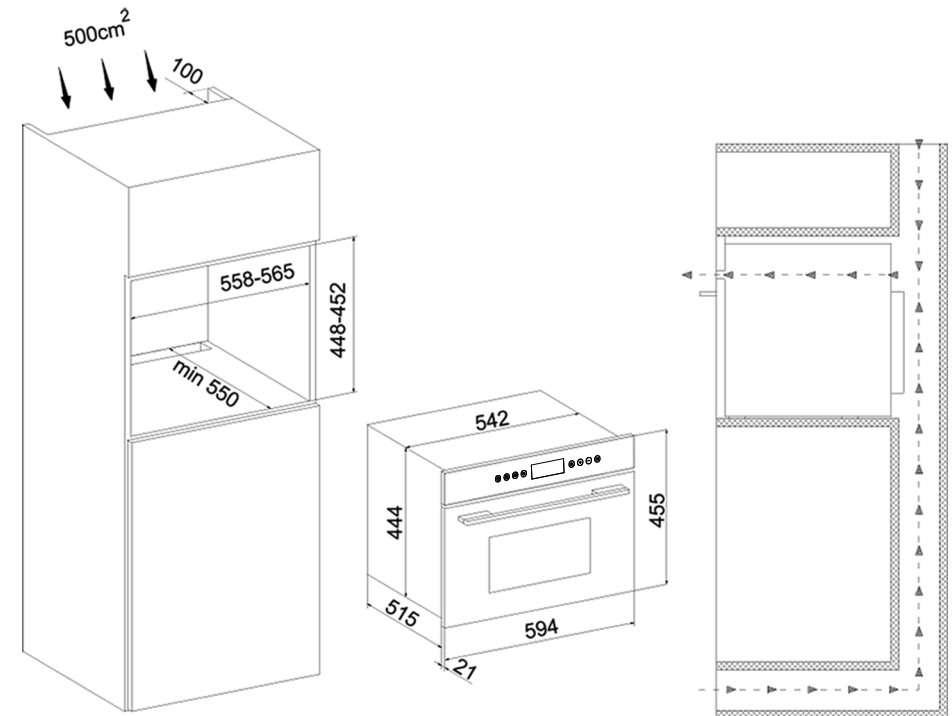

## How to remove the oven door

For a more thorough clean, you can remove the oven door.

Proceed as follows:

- 1) Open the door fully.
- 2) Lift up and turn the small levers situated on the two hinges.
- 3) Grip the door on the two external sides; shut it slowly but not completely.
- 4) Pull the door towards you, pulling it out of its seat ;  
Reassemble the door by following the above procedures backwards.

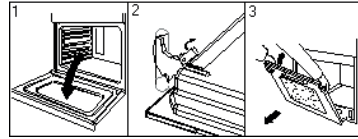

## Replacing the oven Lamp

- 1) Disconnect the oven from the power supply by means of the Omni polar switch used to connect the appliance to the electrical mains; or unplug the appliance if the plug is accessible ;
- 2) Remove the glass cover of the lamp-holder ;
- 3) Remove the lamp and replace with a lamp resistant to high temperatures (300°C)

With the following characteristic.

- Voltage : 220-240V
- Wattage : 25W
- Type : E14

- 5) Replace the glass cover and reconnect the oven to the mains power supply

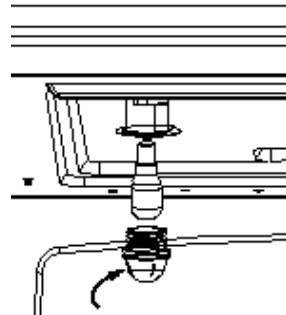

## 10 INSTALLATION

### 10.1 Before the Installation

- Please check the products shell and make sure that there is no trace caused by striking or heavy load.
- The oven door is level, and you can close door flexibly.
- Parameter on the nameplate is in compliance with the relevant regulations. When the oven working in a abnormal way, it must be stopped and unplug the power supply until it has been repaired by a competent person from local agency or factory authorized service. It is hazardous for anyone other than a competent person to carry out any service or repair operation.

- 4.5 Use pan to roast high temperature food such as meat, poultry, fish, others. Place shelf on the pan, when using both pan and grill.

## 5 STRUCTURE DIAGRAM

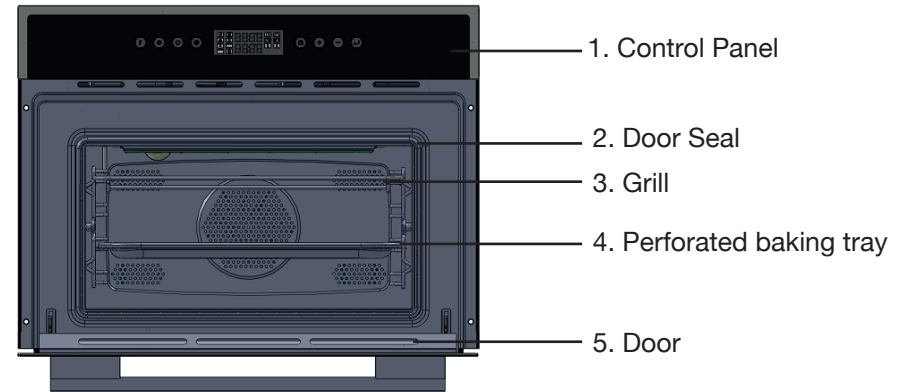



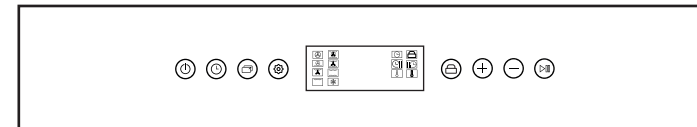











## 6 DESCRIPTION OF FRONT PANEL CONTROLS









- Standby function key
- Baking time setting (baking time, delay time)
- Function adjustment (baking temperature)
- Clock setting (standby time)
- Child lock
- Modifying parameters (function,time,increase temperature)
- Modifying parameters (function,time,decrease temperature)
- Start/Pause

## Functions Description

	Convection Mode		Top and bottom heating elements+ Convection
	Bottom heating element+ Convection Mode		Top and bottom heating elements+ circulation fan
	Top heating element circulation fan		Top and bottom heating elements
	Top heating element		Defrost
	Clock		Child Lock
	Working Time		Delay Time
	Temperature Reached		Heat Up

## 7 PROGRAMM AND FUNCTIONS

### 7.1 Time Setting

When the first use, display screen shows a flashing “0:00; it prompts to set current time. The symbol of clock “” always displays. Press the button “” or “” to increase or decrease the hours; After setting hours press “” to set the minutes. Press “” or “” to increase or decrease the minutes and press “” to confirm the current time.











### 7.2 Setting the current time

Keeping “” pressed for 3 seconds if you want to setting again.

Clock set range: 0:00 - 23:59.

Notice: When you selected functions repeatedly, just leave the appliance away, the appliance will go to standby mode after 5 minutes.

### 7.3 Selecting the oven function

- In standby state, press “” for 1 seconds to function selection mode, press “” and “” to select the desired function, “”, “” will light up, 30:00 and 180°C will appear on the screen.
- Press “” to set baking time, use “” and “” to increase or decrease baking time (89 minutes and 59 seconds can be set as maximum)
- Press “” again to set delay time, the delay time symbol “” will light (For further information about delay time setting, see point ‘Delay Time Setting’)

### 8.8 Defrost Mode “” 1056-1257W

The fan located on the bottom of the oven makes the air circulate at room temperature around the food. This is recommended for the defrosting of all types of food, but in particular for delicate types of food which do not require heat, such as for example: ice cream cakes, cream or custard desserts, fruit cakes. By using the fan, the defrosting time is approximately halved. In the case of meat, fish and bread, it is possible to accelerate the process using the “Baking” mode and setting the temperature to 45°C-75°C.

## 9 CLEANING AND MAINTENANCE

**Before cleaning your oven, or performing maintenance, disconnect it from the power supply.**

**To extend the life of your oven, it must be cleaned frequently, keeping in mind that:**

The enameled or stainless steel parts should be washed with lukewarm water without using any abrasive powders or corrosive substances which could ruin them; Stainless steel could get stained. If these stains are difficult to remove, use special products available on the market. After cleaning, it is advisable to rinse thoroughly and dry.

- The inside of the oven should preferably be cleaned immediately after use, when it is still warm, with hot water and soap; the soap should be rinsed away and the interior dried thoroughly. Avoid using abrasive detergents (for example cleaning powders, etc) and abrasive sponges for dishes or acids (such as lime scale –remover, etc) as these could damage the enamel. If the grease spots and dirt are particularly tough to remove, use a special product for oven cleaning, following the instructions provided on the packet. Never use a steam cleaner for cleaning inside of oven.
- Never line the oven bottom with aluminum foil, as the consequent accumulation of heat could compromise the baking and even damage the enamel.
- Clean the glass door using non-abrasive products or sponges and dry it with a soft cloth.



for example: frozen or pre-cooked food) as well as for a few “home-made” dishes.

### 8.5 Top heating element + Fan Mode “” 1442-1693W





The temperature can be adjusted between 110°C and Max. and the longest time is 90 minutes. The top elements and the fan will come on. The combination of these functions can heat the oven through the air circulation and improve unidirectional heat divergence effect. This is help to avoid burning the surface of food and to let energy into food internal. This mode is recommended for baking shish kebab, sausage, sibs, lamb chop, etc. This mode must close oven door to cook.

### 8.6 Convection Mode “” 2246-2673W

The temperature can be adjusted between 110°C and Max. and the longest time is 90 minutes. The top and bottom heating elements come on. This is the classic, traditional type of oven which has been perfected, with heat distribution and reduced energy consumption. The convection oven is still unequalled when it comes to baking dishes made up of ingredients. For example: cabbage with ribs, Spanish style cod, Ancones style stockfish, tender veal strips with rice, etc. Excellent results are achieved when preparing veal or beef-based dishes as well (braised meats, stew, goulash, wild game, ham etc.) which need to cook slowly and basting or the addition of liquid. It remains the best system for baking cakes as well as fruit and baking using covered casserole dishes for oven baking. When baking in convection mode, only use one dripping pan or baking rack at a time, otherwise the heat distribution will be uneven. Using the different rack heights available, you can balance the amount of heat between the top and the bottom of the oven. Select from among the various rack heights based on whether the dish needs more or less heat from the top.











### 8.7 Top heating element “” 1400-1668W

The temperature can be adjusted between 110°C and Max. and the longest time is 90 minutes. The extremely high and concentration toleration will make your food crisp outside and soft inside. We recommend that this mode is suitable for baking food need high temperature to heat food surface, like: steak, veal, steak, fillet, hamburger, etc.

- Press “” to set temperature, use “” and “” to increase or decrease the desired temperature.
- Press “” to start baking.







Notice: The delay time is the continuation of clock time. For example, if the current time is 10:00 and you want appliance start working after 2 hours, you should set delay time at 12:00, Press the “” key waiting for confirmation.

### 7.4 Delay time

- When “” is pressed to define a delayed start time the corresponding light “” starts to blink. The screen shows the current time “AUTO”. Press “” and “” to set hours, Press “” again to set minutes, use “” and “” to set minutes,
- Press “” to confirm the delayed start time. After pressing “” again the appliance starts working.
- Screen shows the delayed start time, Auto and the current time alternately when the appliance is in standby.
- Press “” for 1 seconds if you want to cancel the selected function.

### 7.5 Pause in the process of baking

Stop baking and change the parameters

- Press the “” start/pause button, can be in baking process stop baking, at this time can be adjusted in the process of baking time and temperature.
- Press the “” standby function key, enter the function menu selection mode, the choice of function.
- Press the “” baking time set key, then press the parameter adjustment increase key “” and reduce the key “” set cooking time.
- Press the “” adjust function keys, switch to baking temperature setting mode;
- Press “” to continue baking.

End baking and cancel the program

- In each function after baking, electronic board buzzer “drop, drop, drop” ring 3 sound, screen shows “End” (End) scintillation display, in 5 minutes intervals of 30 seconds buzzer “drop, drop, drop” ring 3 sound, screen shows “End” has been flashing, 5 minutes after the prototype into standby state; Or press the “” start/pause button, prototype into standby mode.

- In the setup program or in the working process of the press “

### 7.6 Demo function

The oven in standby state, press and hold “

### 7.7 Child Lock

**Lock** : In waiting state, press “

**Unlock** : Pressing “

### 7.8 Cooling fan system

The appliance is equipped with a cooling system which comes into operation as soon as a baking function starts. This system will start after temperature has been reached set. Operation of the fans generates a normal air flow which comes out above the door and may continue for a short time even after the appliance is switched off.

Notice: When the furnace temperature less than 75 degrees, the cooling fan system will stop to work.

### 7.9 Lamp

The furnace lamp always light when the oven is operation except pause.

## 8 OVEN FUNCTIONS

### 8.1 Convection mode “ The temperature can be adjusted between 110°C and Max and the longest time is 90 minutes. The back heating elements and fan will come on to ensure the heat remains constant uniform throughout the oven. The model is suitable for baking delicate food, such as cream puff, sweet biscuit, sponge cake, etc.

### 8.2 Multi-baking mode “ The temperature can be adjusted between 110°C and Max. and the longest time is 90 minutes. The top bottom and back heating elements, as well as the fan ,will come on alternately .Since the heat remains constant and uniform throughout the oven ,the air cooks and browns food uniformly over its entire surface, so food can be put in different level to roast. The model is suitable for baking bread or other foods which need long time to cook, such as lasagna, panettone, chicken and potatoes.ect.In addition, this mode will turn down the temperature to avoid water losses and make barbecue more fragrant crisp. This heating mode is particular suitable for baking fish You can add right amount of condiment to keep fish tasted great.

### 8.3 Pizza Mode “ The temperature can be adjusted between 110°C and Max. and the longest time is 90 minutes. The bottom and back heating elements, as well as the fan, will come on. The combination of these functions can make the oven temperature lifts quickly since the oven will provide a lot of energy, the bottom and back heating elements will come on alternately when keeping warm status, the pizza mode is ideal for foods requiring high temperatures to cook, like pizzas and large roasts.

### 8.4 Fast Baking Mode “ The temperature can be adjusted between 110°C and Max. and the longest time is 90 minutes. The top bottom and back heating elements, as well as the fan ,will come on alternately ,guaranteeing constant heat distributed uniformly throughout the oven. This mode is especially recommended for baking pre-packed food quickly (as pre-heating is not necessary), such as