

LEBENSSTIL
KOLLEKTION

Distributed by:

Kollektion Distribution Sdn.Bhd.(596854-A)

Lot 11B,Jalan 223,Section 51A,

46100 Petaling Jaya,

Selangor Darul Ehsan,Malaysia.

Tel: +603-7954 5200 Fax: +603-7954 5705

www.kollektion.com.my

Careline
1-800-881-770

LEBENSSTIL
KOLLEKTION

Instruction Manual

Model:LKSF-9705RD

LKSF-9705MT

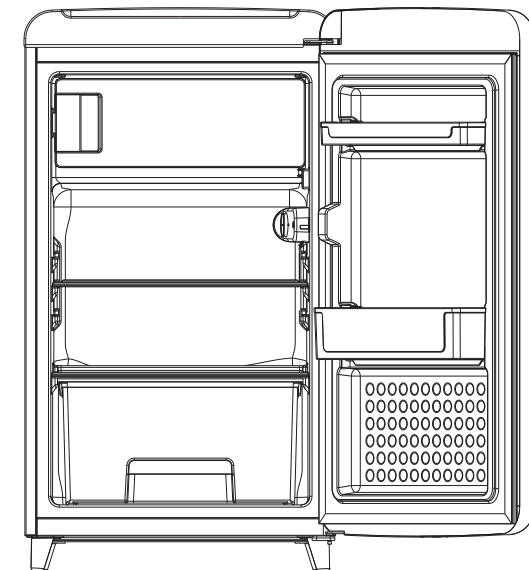

Before operating this unit, please read these instructions completely.

Contents

Cautions-----	2~4
Diagram-----	5
Preparation-----	5
Operation-----	6
Instruction-----	7~9
Defrosting, cleaning and de-commissioning-----	10~11
Questions and Answers -----	12
Product data sheet -----	13

Product Specification

Trade mark	Lebensstil Kollektion	
Model	LKSF-9705RD	LKSF-9705MT
Color	Red	Mint
Rated Voltage	220-240V~	220-240V~
Rated Frequency	50Hz	50Hz
Power Input	110W 0.9A	110W 0.9A
Frost-free	NO	NO
Climatic class	T	T
Product Dimensions (W x D x H)	543 x 615 x 978mm	543 x 615 x 978mm

Cautions

Disposal of the old appliance

*Before disposing an old appliance, please make sure it's not functioning and safe. Unplug the appliance and remove or destroy all springs, latches, or bolt-locks in order to avoid the risk of child entrapment.

*Refrigeration system contains insulating gases and refrigerants, which require specialized waste disposal. Materials contained in a refrigerator can be recycled.

Contact your local waste disposal center for proper disposal of an old appliance.

*Please ensure that the pipe of your refrigerator does not get damaged prior to being picked up by waste disposal center.

Disposal of the packaging of your new appliance

*All the packaging materials employed in the package of your new appliance may be disposed without any danger to the environment.

*The cardboard box may be broken or cut into smaller pieces and given to a waste paper disposal service. The wrapping foil is made of polyethylene and the polyethylene pads and stuffing contain no fluorochloric hydrocarbon.

*All these materials may be taken to a waste collecting center and used again after adequate recycling.

*Consult your local authorities for the name and address of the waste materials collecting centers and waste paper disposal services nearest to your house.

Safety Instructions and Warnings

*This appliance is intended to be used in household and similar applications such as - staff kitchen, offices, residential type environments.

This appliance can be used by children aged from 8 years and above and persons with reduced physical, sensory or mental capabilities or lack of experience and knowledge if they have been given supervision or instruction concerning use of the appliance in a safe way and understand the hazards involved. Children shall not play with the appliance. Cleaning and user maintenance shall not be made by children without supervision.

Before starting the appliance, read the information given in the User's Guide carefully.

The User's Guide contains very important observations relating to the assembly, operation and maintenance of the appliance.

Keep the User's Guide in a safe place and remember to hand it over to the subsequent owner, if you ever sell the appliance.

The manufacturer does not accept responsibility for any damages that may arise due to non-compliance of the following instruction.

Damaged appliances are not to be put into operation. In case of doubt, consult service centre

Before setting up the appliance check it for any externally visible damage. Do not install and use a damaged appliance. It could be dangerous.

***I**f the connection cable is faulty it must only be replaced by an authorised service technician to protect the user from danger.

Cautions

*This appliance contains the coolant isobutane(R600a),a natural gas which is environmentally friendly.Although it is flammable,it does not damage the ozone layer and does not increase the greenhouse effect.The use of this coolant has,however,led to a slight increase in the noise level of the appliance.In addition to the noise of the compressor,you might be able to hear the coolant flowing around the system.This is unavoidable,and does not have any adverse effect on the performance of the appliance.Care must be taken during the transportation and setting up of the appliance that no parts of the cooling system are damaged.Leaking coolant can damage the eyes.

In the event of any damage:

- avoid open flames and anything which creates a spark.
- disconnect from the mains.
- air the room in which the appliance is located for several minutes and contact the Service Department for advice.

*Connection and installation of the appliance are not to be carried out in strict compliance with the relative instructions set forth in the Use's Guide.

*For the purpose of safety,the appliance must be properly grounded in accordance with specifications.

*Always remember to unplug the appliance before cleaning.To disconnect the appliance, pull at the plug itself not the cord.

*Keep alcoholic beverages in airtight bottles or containers and always store in an upright position.In addition,do not store any explosive substances inside the appliance-Danger of explosion!

*Do not damage any parts of the appliance that carry refrigerant by piercing or perforating the refrigerant's grooves with sharp or pointed items,crushing or twisting any tubes,or scraping the coatings off the surfaces.If the refrigerant spurts out and gets into eyes,it may result in serious eye injuries.

*Do not obstruct or cover the ventilation grille of the appliance.

*Do not allow children to play with the appliance.In no case should children be allowed to sit on the drawers or hang onto the door.

Should you have bought your new fridge/freezer to replace an old appliance,please make sure that all existing latch-or bolt-locks on the old appliance are destroyed,before you dispose of it.

This will ensure that a child cannot get trapped inside.

Please have the old appliance ecologically disposed of by a company specialised in environmental protection,since the appliance may contain harmful components in the refrigerant and this must be removed with special equipment.Please check with your dealer.

Make sure that the refrigerating system containing the refrigerant,especially the heat exchanger at the back of the appliance,is not damaged during transportation to the disposal or collection site,so that you can be sure that the refrigerant does not leak out. Details concerning the type of refrigerating/isolating agent used can be found on the appliance's rating plate.

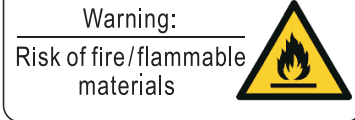

Questions and Answers

Operation Notes

- * The temperature of the refrigerator and the compressor will rise and the compressor will run for comparatively longer periods when the refrigerator is first started.
- * Wipe water drops on the external surface of the refrigerator with a soft cloth.
- * When the refrigerator is opened frequently or stay open too long in humid seasons, the cavity will be dampened.
- * A slight sound will be heard when the liquid refrigerant circulates or when the compressor switches on and off.
- * A slight sound will be heard when defrosted water drops into the evaporating dish.
- * The compressor will operate for comparatively longer periods if excessive quantities of food are stored or the ambient temperature is high.
 - * The evaporator will produce odors if the compartment is not cleaned.

Caution: *The refrigerator should never be restarted until a period of at least five minutes has elapsed.*

Please determine the cause of the problem before making any repairs.

Fault	Causes
Refrigerator will not start.	<ul style="list-style-type: none">* Bad connection to power source (plug, socket and fuse)* The temperature knob is at the 0 position* Low voltage
The lamp does not blink.	<ul style="list-style-type: none">* Bulb failure* Power supply not connected* The temperature knob is at the 0 position
Excessive noise.	<ul style="list-style-type: none">* Uneven placement* Contact between the refrigerator and a wall or other article
Compressor operates for a long period / Temperature does not reach set point.	<ul style="list-style-type: none">* First time of operation* Excessive food stored* Frequent opening of the refrigerator door due to hot weather* The temperature controller is not set properly* Refrigerator is in direct sunlight, or close to a heat source* Poor ventilation, or dirt on the condenser
Food dry	<ul style="list-style-type: none">* Food not properly covered or sealed
Strange odor	<ul style="list-style-type: none">* Failure to seal food properly* Rotting food inside refrigerator* Refrigerator should be cleaned. See "Cleaning"

Defrosting-Cleaning-De-commissioning

Power failure

Even in summer, food can be stored in the refrigerator for a few hours after a power failure.

* Don't put additional food into the refrigerator during a power failure.

* Avoid opening the door during power failures.

*If prior notice of a power failure is given, make some ice and put it in a container in the top of the cold storage compartment.

Caution: *temperature in the refrigerator will rise during a power failure or in the event of technical problems, and the storage period will be reduced.*

During Vacations

* Remove any food from refrigerator if the vacation is short. Turn the temperature selection knob to the proper position, and make sure that the door of the refrigerator is properly closed.

* If the vacation is long, take out the food from the refrigerator and disconnect the power. When the frost inside melts, clean and dry the compartment.

Discarding

* Remove the door of the refrigerator when you get rid of it, in case children may get trapped in.

Moving the refrigerator

* Unplug the refrigerator

* Remove any food

* Tighten the shelf and vegetable tray with tapes

*Tightly close the door with tape

Cautions

*It is necessary to have the plug accessible after installation.

*If the supply cord is damaged, it must be replaced by a supplied cord or assembly available from the manufacturer or its service agent.

*Connection of power supply and installation should be conducted in accordance with the instructions in the operation manual.

*Only the tools regulated by the manufacturer can be used for defrosting.

*The appliance has to be unplugged after use and before carrying out user maintenance on the appliance .

*Do not store explosive substances such as aerosol cans with a flammable propellant in this appliance.

*Warning:Keep ventilation openings in the appliance enclosure or in the structure for building in, clear of obstruction.

*Warning:Do not use mechanical devices or other means to accelerate the defrosting process, other than those recommended by the manufacturer.

*Warning:Do not damage the refrigerant circuit.

*Warning:Do not use electrical appliances inside the food storage of the appliance.

Specifications

*This appliance is designed for food refrigeration, ice making and frozen food storage.

*It is intended strictly for household use. If using it for industrial or commercial purpose, warranty will be void.

*The refrigerating circuit is leak-proof.

Refrigerator Diagram - Preparation

- 1.Shelves
- 2.Vegetable and fruit tray
- 3.Temperature Controller
- 4.Egg tray
- 5.Bottle racks
- 6.Adjustable screw(left)
- 7.Adjustable screw(right)

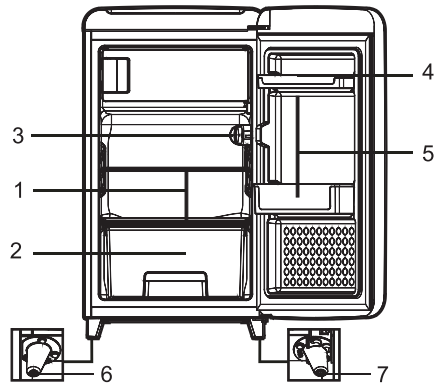

This diagram may vary slightly with the layout of the refrigerator you have just purchased due to technical improvements.

Preparation

Unpacking

Remove all packing materials.

Check attachments and materials

Checking should be conducted with reference to the Packing List. Contact the local distributor if discrepancies are found.

Ensure proper location of the refrigerator.

* Make sure the refrigerator is kept upright during handling. If an inclination is required, it should not exceed 45 degrees. Otherwise the appliance may get damaged resulting not only in compromised refrigeration performance.

* To avoid product damage or personal injury, the refrigerator should be unpacked by two persons after it is located in a previously selected position.

* Before installation, make sure the refrigerator has no visible exterior damage.

* When handling the refrigerator, do not lift it by holding the worktop, to prevent any damage to the refrigerator.

* Do not start up a refrigerator that is damaged.

Clean the refrigerator before use.

(See the following section "Cleaning")

Idle time

After the refrigerator has been sited and cleaned, let it stand for 12 hours before switching on the refrigerator.

Defrosting-Cleaning-De-commissioning

Defrosting the freezer compartment

The freezer compartment is designed for automatic defrosting. Frost formed on the back wall will melt and flow via the drainpipe to the evaporating container over the compressor on the back of the refrigerator, where the heat generated by the compressor will evaporate the water.

ATTENTION: It is recommended to carry out the defrost process before the frost reaching a thickness of 12mm.

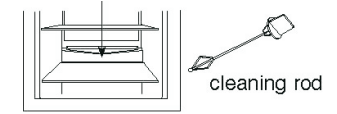

Caution: Always keep the drain over the vegetable and fruit tray clear to ensure the normal flow of defrosted water. Use the rod provided to clear any blockages.

Cleaning

The refrigerator should be cleaned regularly to prevent the formation of bad odors.

* Disconnect the power before cleaning the refrigerator.

* Do not use a hard brush, steel brush, detergent, gasoline or other solvents, hot water, acid or alkali for cleaning.

* Wipe water drops on the surface of the refrigerator with a soft cloth.

(1) Do not use excessive amounts of water for cleaning the refrigerator

(2) Use a dry cloth to clean the switch, the lamp and the temperature controller

* Always keep the rubber door seal clean

* Clean the back and sides of the refrigerator regularly.

Cessation of Operation

If the power failure lasts for an extended period, unplug the refrigerator and clean the refrigerator as previously described.

Keep the door of refrigerator open when the power is turned off to prevent any food remaining in the compartment from producing bad odors.

Caution: It is recommended that the refrigerator is not turned off.

Instructions

Instructions for heater switch

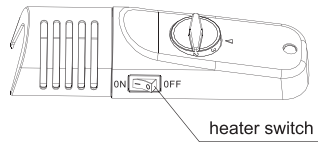

The switch has the following ways:

- In winter, when the room temperature is below 10 °C , to make the refrigerator achieve good cooling effect, set the switch to "ON" position (with the "-" sign side down).When the room temperature is above 10 °C,please dial the switch to the "OFF" position in time,so that it can save energy.
- When you need fast cooling, set the switch to the "ON" position (with the "-" sign side down). When fast cooling is not required, set the switch to the "OFF" position.
- When the standard test refrigeration capacity, the switch must be placed in the "ON" position.

Instructions for freezer

*Storage period will be extended if vegetables are placed with their roots towards the cold source.



*Leaves of carrots or turnips should be removed before storage.

*Put a wad of tissue on the bottle holder before placing bottles on it so that later cleaning is easier.

*Onions, garlic, ginger, water chestnuts and other root vegetables should not be stored in the refrigerator,as these foods are suitable for long-term storage at normal temperatures.



*Ripe squash, melon, papaw, bananas and pineapples should not be stored in the refrigerator.Freezing will accelerate the ripening process.



Operation

Starting the refrigerator

After connecting to the power supply, turn the temperature controller clockwise from position 0 to any position between 1 and 7 to start the refrigerator. The refrigerator compressor will stop when the temperature controller is at position 0.

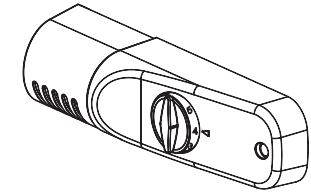

Adjusting the temperature:

The temperature inside the refrigerator is adjusted by turning the temperature controller. Positions 1 to 7 represent different temperatures from the lowest to the highest.

Position	Conditions
1-2	Summer or ambient temperature between 25-35°C
3-4	Spring, autumn or ambient temperature between 15-25°C
4-5	Winter, or ambient temperature between 5-15°C
6-7	Quick freeze

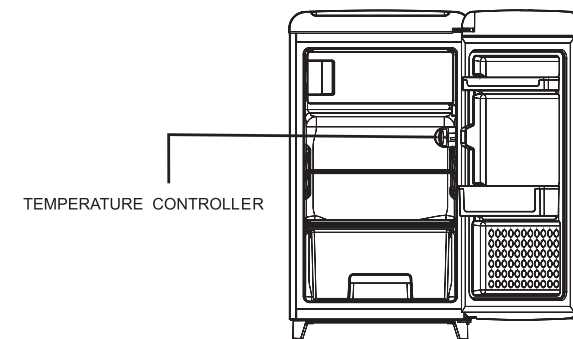

Caution: Some time will be required for the refrigerator to reach the set level when temperature adjustments are made. The length of this period is determined by difference in the existing and set temperatures, the ambient temperature, the frequency with which the door is opened and closed and the amount of food in storage.

Loading the refrigerator with food

When the refrigerator is switched on, do not load food until 1~2 hours have passed. Usually, food for cold storage or deep freezing can be loaded when the temperature inside the compartment reaches the set point.

Instructions

Freezer is for short-term food storage or for daily consumption.

Although the temperature in most parts of the freezer compartment can be regulated between 0 and 10 degrees Centigrade, extended periods of freezer is not recommended. Freezer should only be used for short-term storage.



Freezer compartment

1. Eggs and butter
2. Pickled food and seasonings
3. Beverages and bottled food
4. Cookies, cooked food and milk
5. Meat and sausages
6. Fruits, vegetables and salads

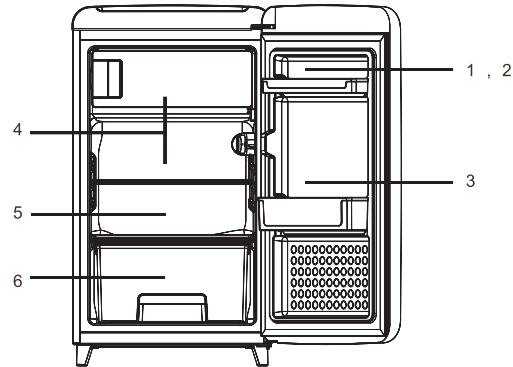

Cautions for freezer

* Hot food must be cooled to room temperature before storing in the refrigerator.



Dry any water droplets on the food before placing it in the refrigerator.

It is recommended that food be sealed in suitable storage bags before being placed in the refrigerator; this will prevent moisture in the food from evaporating and prevent vegetables and fruit from withering or altering in flavor.

Instructions

* Do not store excess quantities or weights of food; food should be stored with spaces in between for better storage results. Never overload shelves, as they may collapse under excessive loads.

* Food to be stored should be sorted according to consumer requirements. Food consumed daily should be placed in the most convenient area, this will minimize opening periods for the door. Do not place food too close to the internal walls.

Food Holder Cleaning

* Food holders can be taken out for cleaning

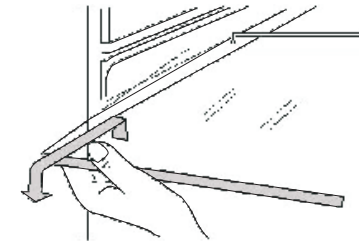

Lamp:

*Lamp: 220-240V, 15W

* If the interior light in the refrigerator section is not working.

- Disconnect the appliance from the mains. Switch off at the wall and withdraw the plug from the socket, or disconnect the mains fuse or remove the screw-out fuse in countries where this applies.
- Grasp the lamp cover at the top and at the bottom(1), and pull it forward to remove(2).
- Unscrew the lamp.
- Change the lamp.
- Screw the new lamp into the connection. Make sure the safety catch is correctly fitted.
- Replace the lamp cover, and click it into place at the sides.

